

MODEL 100 TRAMP METAL DETECTOR

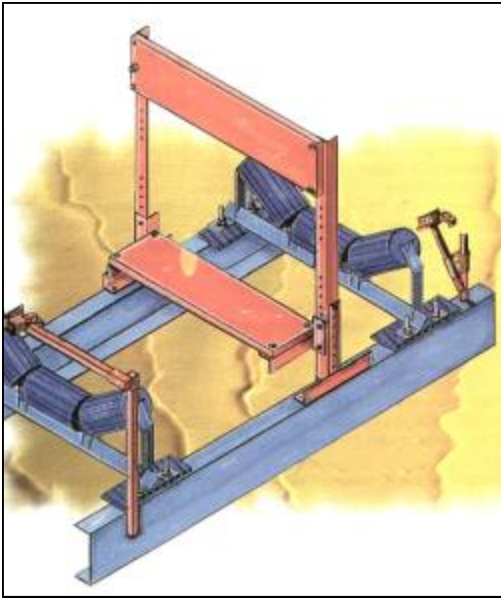

The **Model 100 Tramp Metal Detector**, when installed on a conveyor system, provides protection to downstream processing equipment by detecting the presence of potentially damaging metal objects. It is designed to detect all types of tramp metal, magnetic, non-magnetic, ferrous and non-ferrous. Metal splices and or repair clips can be used with the metal detectors.

The **Model 100** is prefabricated to fit onto most standard CEMA conveyors. The aperture is adjustable up to 22", which will accommodate a maximum burden depth of 18".

The sensing antennas are encased in high strength, compression molded fiberglass, and are supported by structural pultruded fiberglass up-rights with steel mounting feet.

The electronics are constructed with reliable solid state circuitry. The system is rugged, lightweight, compact, easily installed and maintained. The **Model 100** incorporates the design and reliability of all Bulk Pro Systems Metal Detectors.

Features

- **Flexible Design**
- **Economically Priced**
- **Easy Installation, No Need To Cut the Belt**
- **Optional Clip Detector**
- **Field Replaceable Modules**
- **Uniform Sensitivity**

Benefits

- **Microprocessor Based Electronics**
- **Bar Graph Display**
- **Membrane Keypad and Function LED's**
- **Multilanguage Available**
- **Remote Operation Capability**
- **Three Level Password Protection**
- **Event Log**
- **EEPROM Stored Parameters**
- **Self-Test Circuit with Fault Alarm**
- **Noise Reduction**

SPECIFICATIONS

Input Voltage:	120/220 VAC, 50/60 Hz
Power Required:	
No Output Load	35 Watts
Max Output Load	990 Watts
Output Signals:	
Direct Output	Dry Contacts (SPDT) Rated 3Amps @ 250VAC
Timed Output	Dry Contacts (SPDT) Rated 3Amps @ 250VAC
Fault Output	Dry Contacts (SPDT) Rated 3Amps @ 250VAC
Sensitivity Drift:	Less than 10%
Dust and Humidity:	No Restrictions
Operating Temperature:	-14° F (-10° C) to 120° F (+50° C) Electronics (Cold Weather Option Available) -40° F (-40° C) to 138° F (+60° C) Coil Operating Temperature
Enclosure Rating:	NEMA-4
Interconnecting Cable:	25' Standard Length
Antenna:	Dual Antenna System
Warranty:	3 Years From Date of Shipment

Examples of Industrial Applications for the Bulk Pro Systems Model 100 Tramp Metal Detector

- **Aggregate** Protects Impact Crushers
- **Asphalt** Protects Impact Crushers
- **Mining** Protects Impact Crushers
- **Wood Chips** Protects Hogs and Impact Crushers
- **Waste Wood** Protects Hogs and Impact Crushers

Protect your crusher
from tramp metal!

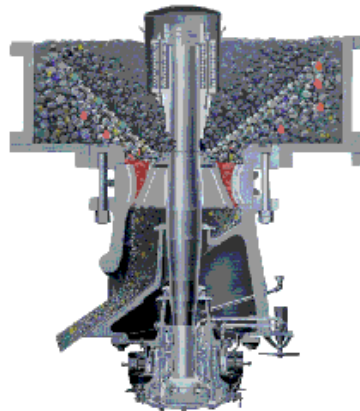

The Model 100, when installed on a conveyor system, provides protection to downstream equipment by detecting the presence of potentially damaging metal objects. It is designed to detect all types of tramp metal.



P.O. Box 337 P: 905-888-0063 F: 905-888-6381
14 Gormley Industrial Ave. Unit #5
Gormley, Ontario L0H-1G0 Canada
E-Mail: sales@aciltd.ca Website: WWW.ACILTD.CA

Doc 1057 Rev A