



THAYER SCALE

CONTINUOUS WEIGHING & FEEDING OF BULK MATERIALS

FORCE MEASUREMENT
FMSS
SUSPENSION SYSTEM

Two Idler Model 2LLRF-4A Conveyor Belt Scale
specifically designed for **LIGHT LOADING APPLICATIONS**

SIMPLY THE HIGHEST PERFORMANCE BELT SCALES ON THE PLANET

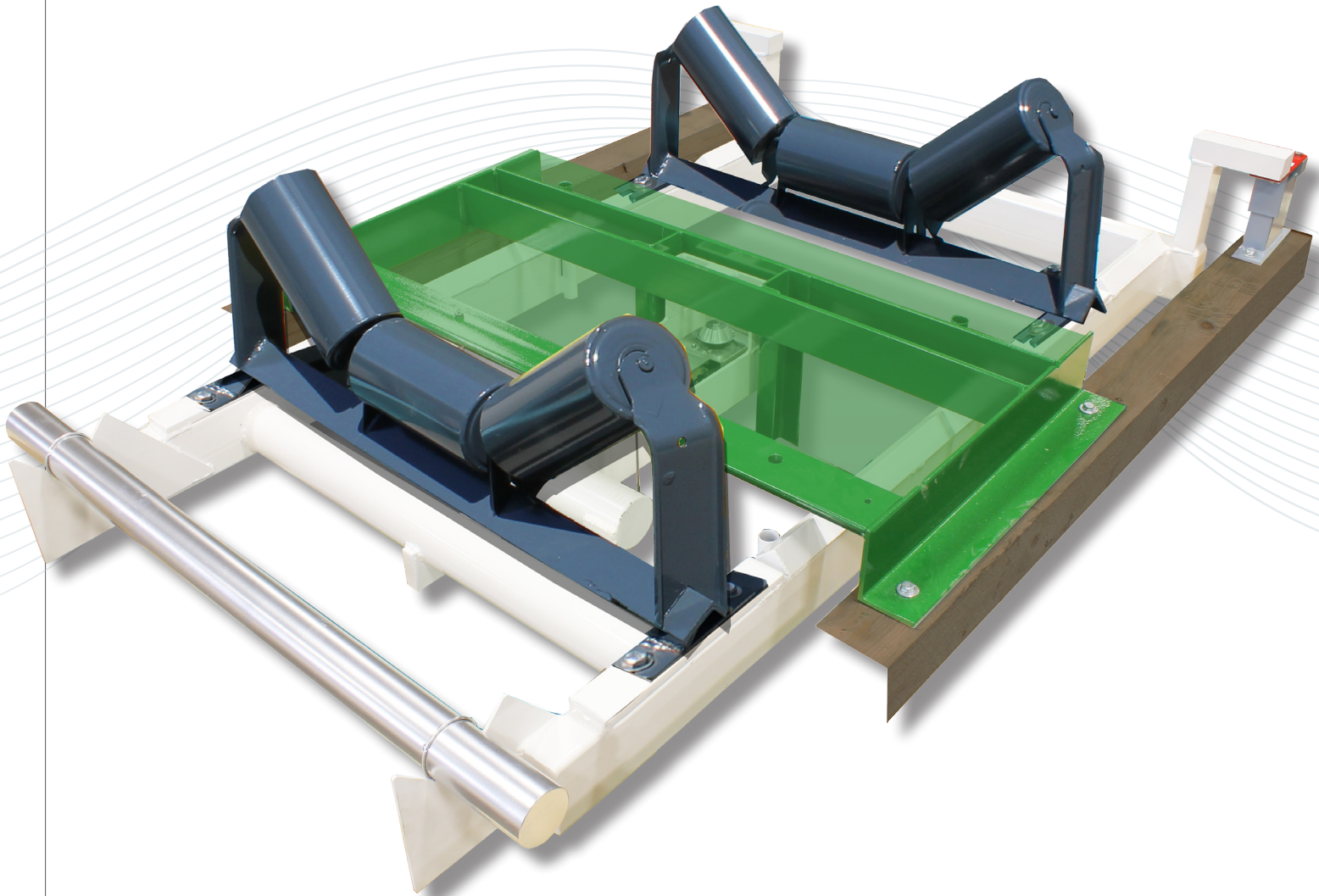

Two Idler Model 2LLRF-4A Conveyor Belt Scale for light loading applications

THAYER 2 Idler Rocking Flexure Belt Scale Features & Benefits:

Superior Performance

The THAYER models 2LLRF-4A Belt Scale is designed for high accuracy (1/4% typical) inventory control and totalization of applications where the lb/ft loading on the conveyor is lower than 10 lb/ft. The weighbridge features exclusive rocking flexure suspension in the approach configuration. Measurement sensitivity is high, deflection is low, and the load cell is isolated from the error-inducing effects of extraneous lateral forces, off-center loading, foundation distortion, inclination hold-back forces, and high sporadic shocks and overloads. Tare load is mass counterbalanced to create superior signal to noise ratio in weight sensing, orders of magnitude better than belt scale designs supporting full tare load on the load sensor.

- Depth of suspension member is 6 inches to meet deflection criterion.
- Mass counterbalance weights are used to counterbalance the dead load of the main frame weigh idlers and conveyor belt. The use of the mass counterbalance permits maximum utilization of the load cell.
- Special pentagonal (5-sided) tubular stringers employed to meet combination needs of tensional/bending rigidity and low material build-up area.
- Patented rocking-flexure primary pivot is wearless and uniquely accommodates a distorting foundation (as is characteristic of typical conveyor structures).
- Isolation lever suspended by stainless steel pre-stressed aircraft cable protects load cell from extraneous forces that arise from distorting foundation and serves to provide means to optimize load cell utilization factor.
- Patented calibration method utilizing a controlled belt travel interval makes one-shot adjustment possible.
- Unique test weight system eliminates need for test chains or massive test weights.
- A typical equipment package includes scale suspension, load sensor and belt speed transmitter.

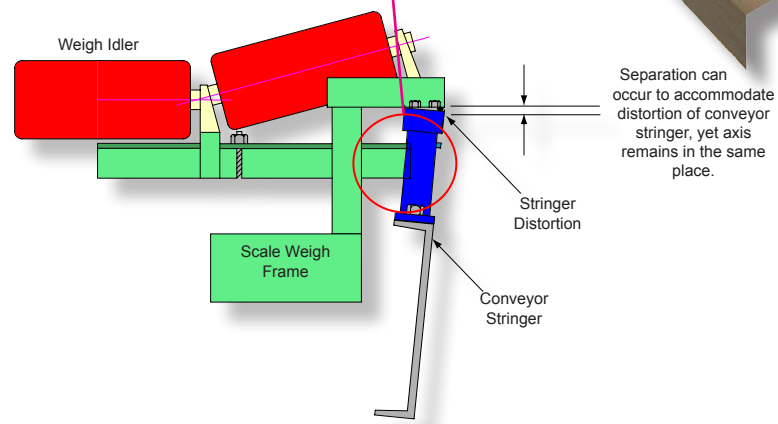
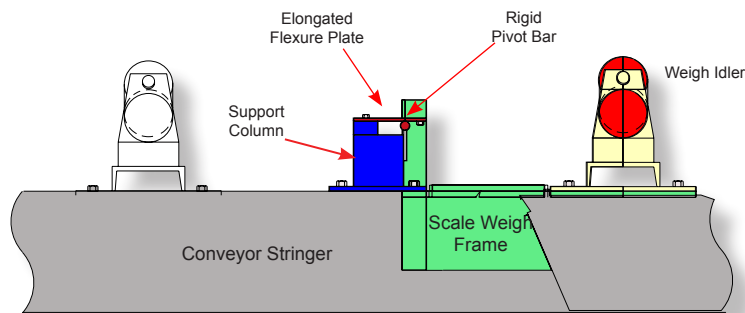

THAYER Load Cell Utilization Factor

The distinct specification of continuous belt scale weighing applications and the unique environment and operational issues those applications typically encounter, places too many requirements on the load sensing system for any single technology to completely satisfy. Therefore, using THAYER'S exclusive FMSS technology in the design of its belt scale suspension system allows the choice of using either its LC-137 LVDT Load Cell or its LC-174 Strain Gauge Load cell. This puts Thayer in a unique position that allows us to offer equipment to match a wide range of applications such as light material loading, severe environmental conditions, and commercial certification.

The performance of a load cell and its instrumentation is specified on the basis of the load cell's rated output. If the load cell is supporting a quantity of dead-weight (i.e. idlers, belting, suspension system) and has been further oversized to accommodate problems of overload protection, off-center conveying, shock, vibration and negative integration, then the amount of range left to do the job of weighing is only a fraction of the cell's rated output. The percentage of the load cell's rated output reserved for the actual job of weighing material is called the LOAD CELL UTILIZATION FACTOR.

Thayer's "RF" Belt Scales with "FMSS" Force Measurement Suspension System mass counter balance technology assures better than 80% Load Cell Utilization.

Provides :

- Field adjustable mechanical TARE balancing of dead loads typically as high as 200 times NET loads, thereby providing the full utilization of the load cell force range.
- Reduces deflection of load receptor to a fraction of load cell deflection.
- Reduces zero shifting as a result of foundation distortion.
- Provides preferred access location of load cell for inspection or removal.
- Simplifies the application of test weights for calibration/performance verification.

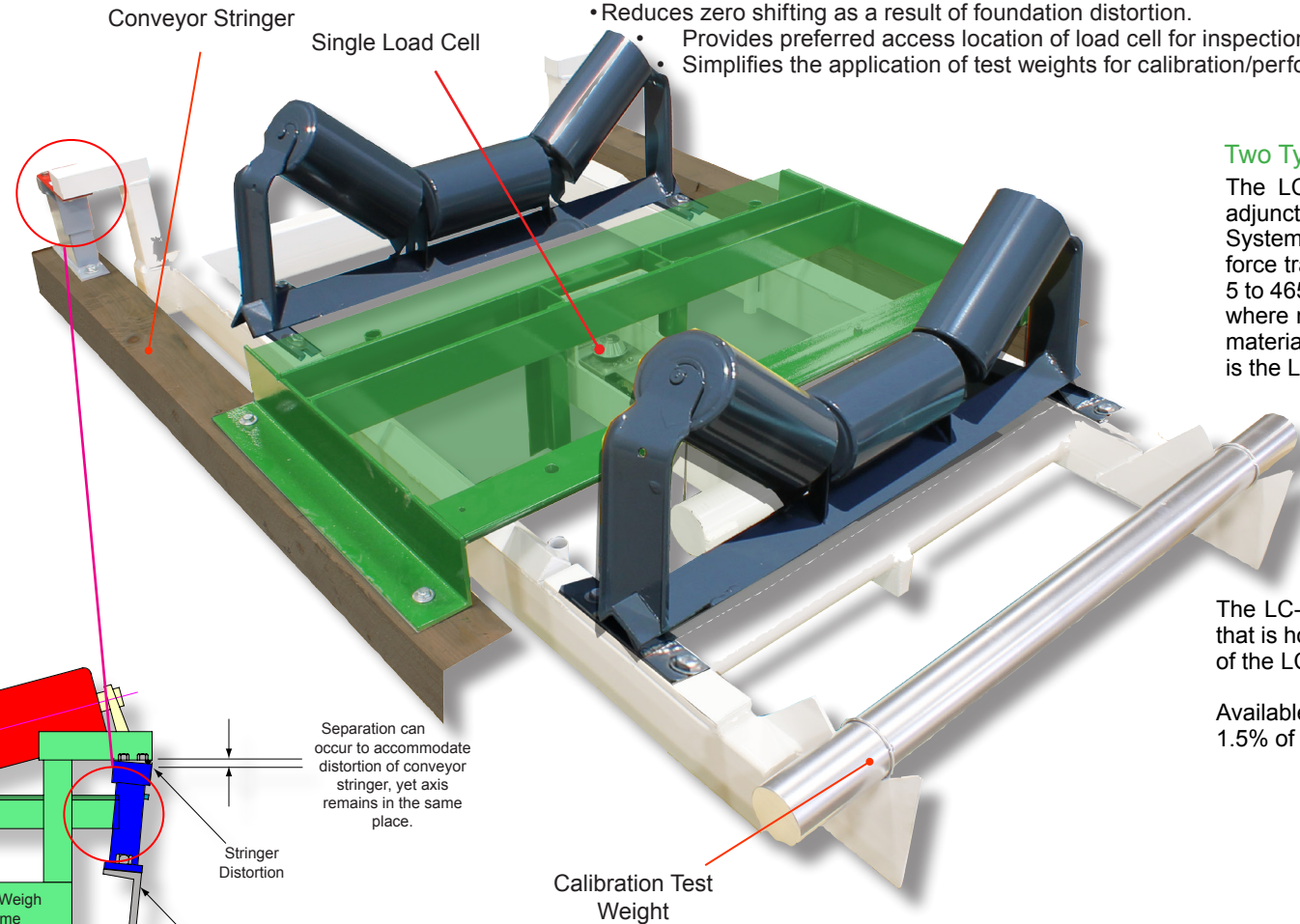

Two Types Of Load Cells To Choose From

The LC-137 (LVDT) Load cell was specifically developed as the ideal adjunct to THAYER'S "reverse-action" Force Measurement Suspension System. It is essentially a precision and extremely durable "tension-style" force transducer that is manufactured in a fine series of force ranges from 5 to 465 lbs. The LC-137 is the ideal load cell for "light loading" applications where mechanical tare loads represent as much as 10 to 40 times the net material load and provide unparalleled at 200% of rated output. So superior is the LC-137 Load Cell that it is guaranteed for 15 years.



The LC-174 Load Cell is a conventional Strain Gauge "S" Beam Load Cell that is housed in an enclosure that has identical mounting dimensions to that of the LC-137.

Available in force ranges from 25 to 2,000 lbs with an overload protection of 1.5% of rated output.

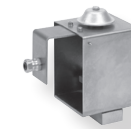

THAYER LC-174 Strain Gauge Load Cell

THAYER'S RF Flexure Suspension (patented)

The axis position is permanent, being held in its horizontal position by the flexure plate and in its vertical position by the load rod which bears on the flexure plate, which in turn is bolted to the bottom side of the square and elevated suspension extension shaft.

There is insignificant rotational hysteresis. While the load rod may be likened to a dull knife edge (it is round), the flexure plate bearing surface directly in contact can rock without sliding through small rotational displacement.

The reaction to lateral forces creates an insignificant moment transfer to the weigh suspension (this is part of the patent). Since the flexure plate (which is hardened blue tempered steel) is also the upper bearing block of the pivot, tensile or compressive forces reacting to lateral forces therein have no moment arm distance to operate.

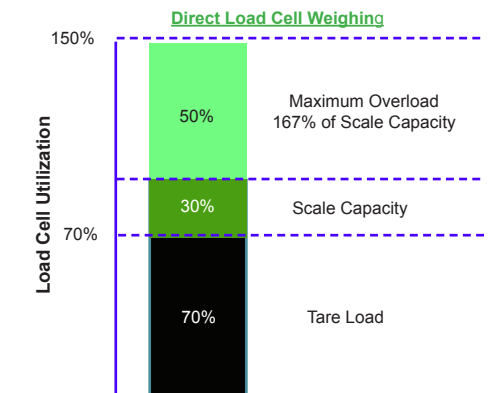
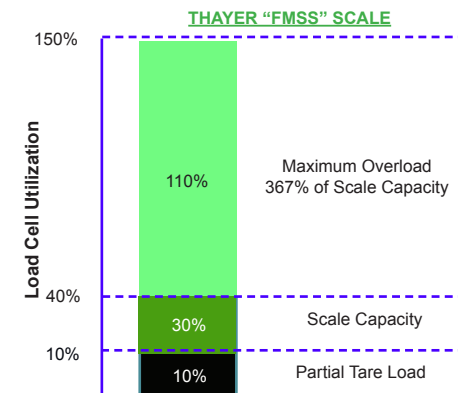

PRECISION BELT SPEED MEASUREMENT--

Accurate belt speed measurement requires the use of a precision wheel and pulser. A spring is used to maintain proper contact pressure of the wheel with the tension side of the belt in all operating conditions. The THAYER belt travel pulser assembly includes a precision cast/machined wheel with a "pre-calibrated" circumferential tolerance of $\pm 0.05\%$ and a high resolution digital transmitter. The transmitter produces pulses equivalent to 1/100 to 1/200 of a foot of belt travel. The speed pick-up wheel has a narrow face width so it is less susceptible to material build-up, which can result in speed measuring errors. Since belt stretch is not constant throughout the length of the conveyor, and therefore, can affect speed measurement, the speed pickup produces a more accurate speed signal than that which is produced by tail pulley mounted speed encoder.

- Digital Pulse Output
- Heavy-duty Construction
- Spring loaded to maintain positive tracking
- Self-cleaning
- Minimum surface area for material build-up
- Easy to install
- Unaffected by temperature and voltage variations

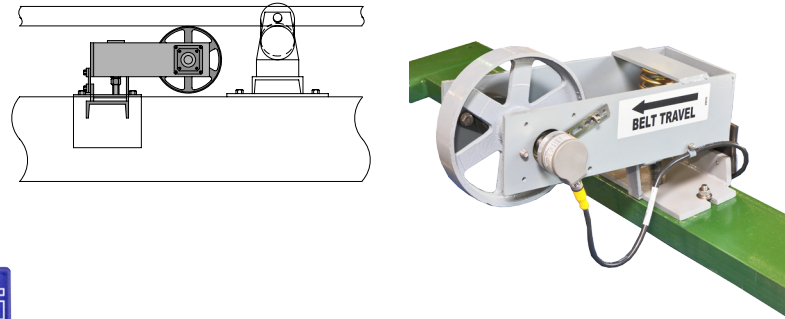

CALIBRATION MADE EASY



CALIBRATION

A belt scale should be thought of as a precision instrument and its performance should be quickly and easily checked. Thayer Scale can provide an accurate reliable calibration using a certified calibration weight instead of test chains or electronic simulation of load, for all scale capacities. Thayer Scale developed and patented the first automatic calibration system for conveyor belt scales in 1971.

For belt scale calibration, Thayer Scale utilizes the test weight which represents a specific pound per ft loading value and an automatic belt length measurement system. This combination produces accurate, repeatable calibrations free from human error. Unlike electronic calibration which simply simulates a load cell output to the instrumentation, the test weight mechanically exercises the scale mechanism. Thayer's unique suspension design assures that the test weight will accurately load the scale and will weigh a maximum of approximately 60 lb (typically much lighter) while still representing 80-100% of full scale load. Calibration time is reduced to a matter of minutes and can be performed by one person.

Key advantages:

- Test Weight more manageable. One man operation.
- Loading effect independent of conveyor incline.
- Longitudinal restraining elements not falsely loaded

CALIBRATION TEST WEIGHT LIFT & STORAGE

Many plants have instituted safety procedures that prohibit operations personnel from being in close physical proximity to moving conveyors. Consequently, routine calibrations can become tedious as lock-out/tag-out procedures must be followed before test weights can be manually re-positioned. As most large conveyor belt drive systems allow for only so many re-starts in a given time frame, the calibration process can become time consuming, requiring extended process down time.

Recognizing that routine calibrations are more likely to be performed on a regular basis if they are easy to accomplish, Thayer Scale offers two different types of test weight placement methods.

A "manual" system and an automated test weight placement system. The manual test weigh lifter requires that the operator lift a lever to change the placement of the calibration weight. When using the Automated Test Weight Lifter (ATWL) the instrumentation automatically re-positions test weights at the proper time during the calibration routine, eliminating the need to stop and re-start the conveyor as well as eliminating the need for operators to be in close physical proximity to high speed conveyors. THAYER's Automated Test Weight Lift (ATWL) and Storage System provides quick, repeatable, and traceable calibration results without the need for operator intervention and with minimal process down time.

The test weight lift and storage assembly provides a safe, convenient method of placing the calibration weight on the scale weigh bridge accurately and provides these advantages.

- SAFE-eliminates need to go between belt strands.
- EASY-permits one person to operate.
- CONVENIENT STORAGE-prevents loss or damage.
- REPEATABILITY-weight is ALWAYS positioned in the same location test after test.



Two Idler Model 2LLRF-4A

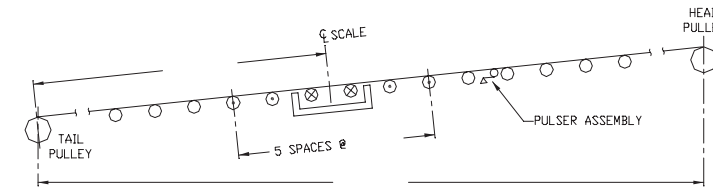
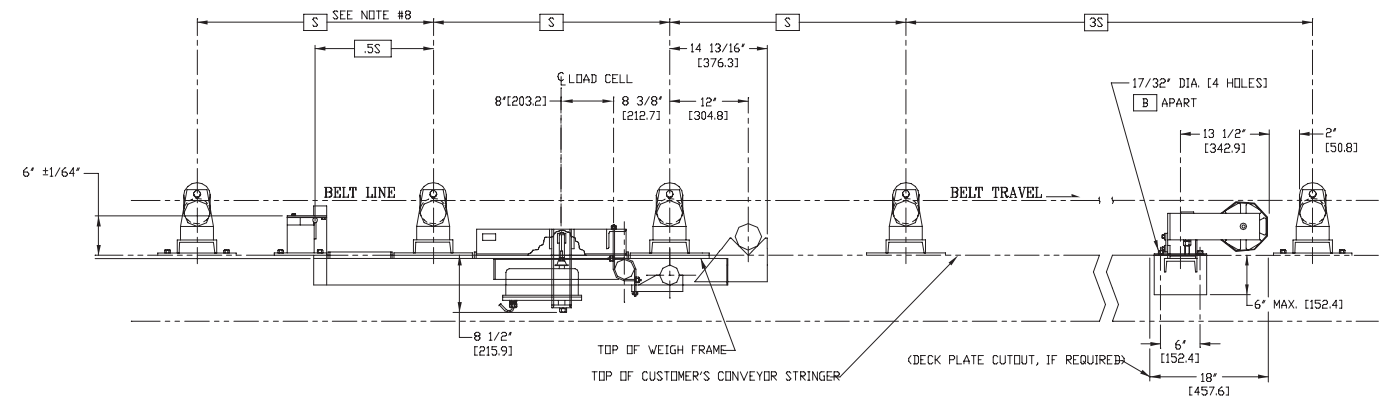
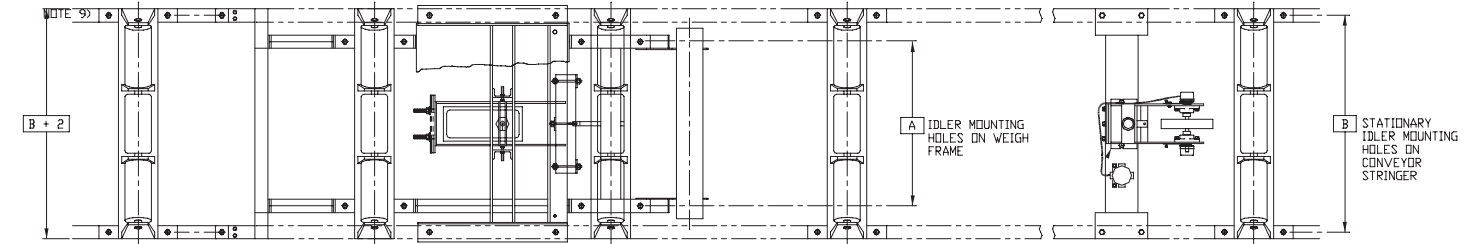

PROFILE

- SCALE QUALITY IDLER
- ⊗ MODIFIED SCALE QUALITY IDLER

MODEL NUMBER	BELT WIDTH	A	B	D
2LLRF-4A-14	14" [355.6]	15" [381.0]	23" [584.2]	17" [431.8]
2LLRF-4A-16	16" [406.4]	17" [431.8]	19" [482.6]	19" [482.6]
2LLRF-4A-18	18" [457.2]	19" [482.6]	27" [685.8]	21" [533.4]
2LLRF-4A-24	24" [609.6]	25" [635.0]	33" [838.2]	27" [685.8]
2LLRF-4A-30	30" [762.0]	29" [736.6]	39" [990.6]	33" [838.2]
2LLRF-4A-36	36" [914.4]	33" [838.2]	45" [1143.0]	39" [990.6]
2LLRF-4A-42	42" [1066.8]	39" [990.6]	51" [1295.4]	45" [1143.0]
2LLRF-4A-48	48" [1219.2]	45" [1143.0]	57" [1447.8]	51" [1295.4]

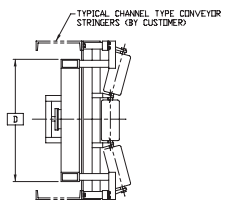

THAYER Belt Scale Applications Program

THAYER is the only belt scale manufacturer that analyzes the customer's conveyor and application data to predict "real-world" performance. The computer program essentially tailors each component of the scale and conveyor to maximize the performance of the complete system based on the specific requirements of the application.

The program considers the parameter variations that are normally experienced in conveyor installations, the lack of dimensional precision of the conveyor components and the installation imperfections occurring as the result of both the initial set up and the subsequent conveyor maintenance activities.

The most logical approach to designing and installing high accuracy belt weighing equipment is to design for minimum error influences in every phase of the project. This involves conveyor analysis work to seek out preferred locations for load and speed measurements within a conveyor, suspension system configurations (scale design) that are least affected by conveyor influences, particularly alignment factors (load deflection vs. installed alignment conditions), and many other factors.

The typical computer analysis involves inputting eleven (11) key parameters which describe the application in sufficient detail to estimate accuracy for the installation as initially defined.

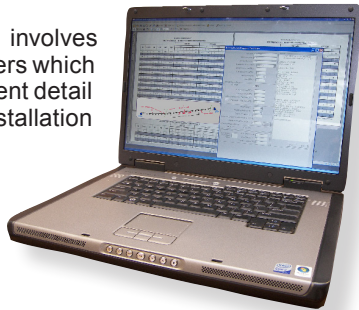

Major factors include:

- Conveyor design,
- Scale suspension design
- Location of load and speed sensors in relation to both conveyor terminal equipment and loading points
- Installed alignment conditions
- Duration and constancy of loading cycle
- Condition of rolling conveyor elements,
- The uniformity and stiffness of the belt itself
- Condition and size of take-up apparatus
- The precision with which the system can be routinely calibrated & adherence to a calibration schedule
- Operating environment.

Subsequent runs are performed to evaluate the effects under various conditions, using different belt scale weigh bridge configurations, weigh bridge locations, idler spacing, weights and locations of gravity take-up, etc.

Actual "bias error" (offset between THAYER totalized weight and check scale weight) and "as-found error" (random error, i.e. repeatability) can be calculated for a given conveyor application using Thayer's belt scale performance math model.

This unique program was developed by THAYER, and is based on many years of experience in the field of high accuracy continuous weighing. The objective of the program is quite simple: To provide a means of producing a high performance Belt Scale installation.

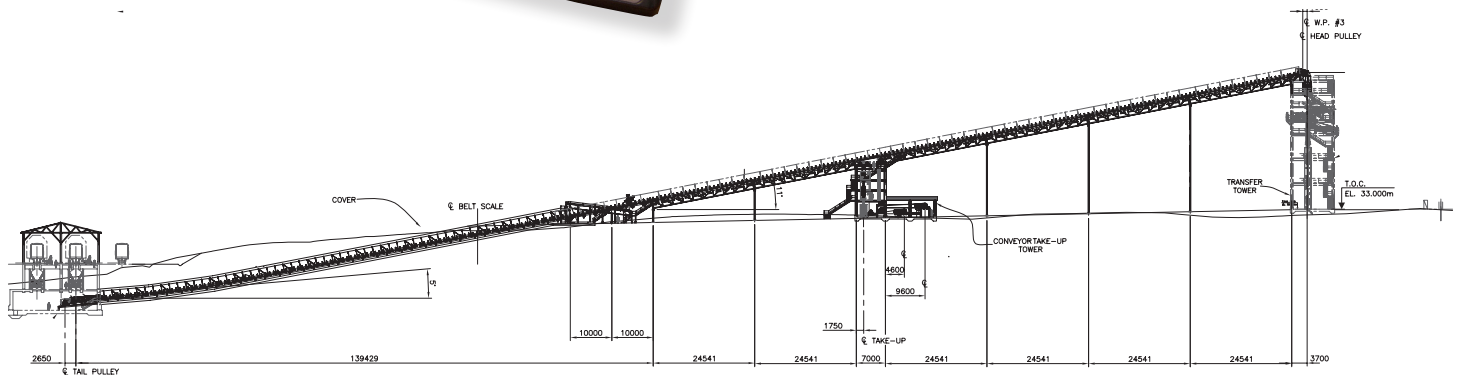

THAYER® and the THAYER logo are Registered Trademarks of Hyer Industries, Inc.
© Hyer Industries, Inc. 2004. All rights reserved

THAYER SCALE-HYER INDUSTRIES, INC.

91 Schoosett St., Pembroke, MA 02359

Ph: 781-826-8101 Fax: 781-826-7944

e-Mail: Sales@ThayerScale.com

WEB: www.ThayerScale.com