



IFC 050 Technical Datasheet

Signal converter for electromagnetic flowmeters

- For water and wastewater applications
- Multiple outputs, incl. active pulse output and RS485 Modbus
- Excellent price/performance ratio



The documentation is only complete when used in combination with the relevant documentation for the measuring sensor.

1	Product features	3
<hr/>		
1.1	The standard for water and wastewater applications	3
1.2	Options and variants	5
1.3	Signal converter / measuring sensor possibilities	6
1.4	Measuring principle.....	6
2	Technical data	7
<hr/>		
2.1	Technical data.....	7
2.2	Dimensions and weights	14
2.2.1	Housing	14
2.2.2	Mounting plate, wall version.....	16
2.3	Flow tables	17
2.4	Measuring accuracy	19
3	Installation	20
<hr/>		
3.1	Intended use	20
3.2	Installation specifications	20
3.3	Mounting of the compact version.....	20
3.4	Mounting of the wall housing, remote version	20
4	Electrical connections	22
<hr/>		
4.1	Safety instructions.....	22
4.2	Preparing the signal and field current cables	22
4.2.1	Signal cable A (type DS 300), construction	22
4.2.2	Length of signal cable A.....	23
4.2.3	Connection diagram for signal and field current cable	24
4.3	Grounding the measuring sensor	25
4.4	Connecting the power supply.....	25
4.5	Overview of outputs	27
4.5.1	Description of the CG number	27
4.5.2	Fixed, non-alterable output versions	27

1.1 The standard for water and wastewater applications

The **IFC 050** was especially designed for measurements in different types of water processes. The signal converter can be used for virtually all water processes from raw water to drinking water.

The signal converter **IFC 050** in combination with the flow sensors is a perfect choice for measuring conductive fluids. The output represents measured values for flow, mass and conductivity.

This low-cost signal converter for the water and wastewater market has some specific features:

- An active pulse output for a simple system, like driving an electro-mechanical counter
- RS485 Modbus communication with a data processing system
- Extra insulation of the electronic device and housing for high performance in areas with extreme humidity and chances for flooding



- ① Large graphic display with 4 magnet keys for operating the signal converter when the housing is closed
- ② 4 push buttons to operate the signal converter when the housing is open
- ③ Supply voltage: 100...230 VAC and 24 VDC

Highlights

- Available outputs: current output (incl. HART®), active pulse/frequency output, status output and Modbus
- Intuitive operation with touch buttons
- Excellent price/performance ratio
- Modern robust housing design
- Asymmetric mounting possible
- All versions with and without display are available
- Simple installation and start-up
- Bright graphic display
- A variety of operating languages integrated as standard
- Certified tests for humidity and vibration
- Extremely quick signal conversion

Industries

- Water & wastewater
- Heating, Ventilation & Air Conditioning (HVAC)
- Agriculture
- Steel

Applications

- Water and wastewater treatment
- Water distribution network
- Irrigation installation
- Water abstraction

1.2 Options and variants

Modular converter concept with display



The modular concept gives the opportunity to combine the IFC 050 with the measuring sensors OPTIFLUX 1000, OPTIFLUX 2000 and the WATERFLUX 3000.

With respect to the housing versions, both a compact and a remote design are available. The signal converter for the compact version is directly mounted under a 10° angle to the measuring sensor for easy reading of the display after rainfall or frost. If the measuring point is difficult to access or if the ambient conditions like temperature effects and vibration prevent the use of the compact version, a remote signal converter with a wall housing is available.

Remote version in wall housing with display



A signal cable is used to connect the measuring sensor to the signal converter for power supply and signal processing.

The same electronic unit can be used in both (C + W) versions without configuration.

Remote version in wall housing without display



A blind version is the perfect option in a situation where the display is not required and the menu will be approached once a time.

A separate display can be easily connected to the electronic unit to enter the menu. This tool will be provided as a spare part.

1.3 Signal converter / measuring sensor possibilities

Measuring sensor	Measuring sensor + signal converter IFC 050	
	Compact	Remote wall-mounted housing
OPTIFLUX 1000	OPTIFLUX 1050 C	OPTIFLUX 1050 W
OPTIFLUX 2000	OPTIFLUX 2050 C	OPTIFLUX 2050 W
WATERFLUX 3000	WATERFLUX 3050 C	WATERFLUX 3050 W

1.4 Measuring principle

An electrically conductive fluid flows inside an electrically insulated pipe through a magnetic field. This magnetic field is generated by a current, flowing through a pair of field coils. Inside of the fluid, a voltage U is generated:

$$U = v * k * B * D$$

in which:

v = mean flow velocity

k = factor correcting for geometry

B = magnetic field strength

D = inner diameter of flow meter

The signal voltage U is picked off by electrodes and is proportional to the mean flow velocity v and thus the flow rate q . A signal converter is used to amplify the signal voltage, filter it and convert it into signals for totalising, recording and output processing.

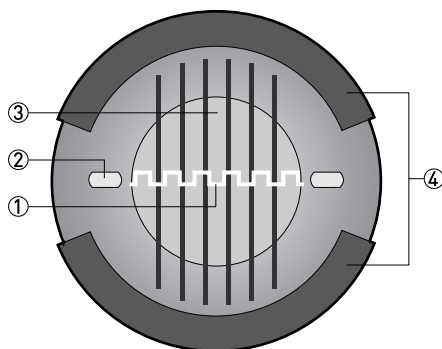

- ① Induced voltage (proportional to flow velocity)
- ② Electrodes
- ③ Magnetic field
- ④ Field coils

2.1 Technical data

- *The following data is provided for general applications. If you require data that is more relevant to your specific application, please contact us or your local sales office.*
- *Additional information (certificates, special tools, software,...) and complete product documentation can be downloaded free of charge from the website (Download Center).*

Measuring system

Measuring principle	Faraday's law of induction
Application range	Continuous measurement of current volume flow, flow velocity, conductivity, mass flow (at constant density), coil temperature of the measuring sensor

Design

Modular construction	The measuring system consists of a measuring sensor and a signal converter.
Measuring sensor	
OPTIFLUX 1000	DN10...150 / 3/8...6"
OPTIFLUX 2000	DN25...1200 / 1...48"
WATERFLUX 3000	DN25...600 / 1...24"
Signal converter	
Compact version (C)	IFC 050 C
Remote version (W)	IFC 050 W
Options	
Outputs	Current output (incl. HART®), pulse output, frequency output, status output and/or limit switch
Counter	2 internal counters with a max. of 10 counter places (e.g. for counting volume and/or mass units)
Verification	Integrated verification, diagnostic functions: measuring device, empty pipe detection, stabilisation
Communication interfaces	HART®
	Modbus

Display and user interface	
Graphic display	LC display
	Size: 128 x 64 pixels, corresponds to 59 x 31 mm = 2.32" x 1.22"
	Ambient temperatures below -25°C / -13°F may affect the readability of the display.
Operating elements	4 push buttons for operating the signal converter when the housing is open.
	4 magnet keys for operating the signal converter when the housing is closed.
Remote control	Only generic and not device-specific DDs and DTMs available!
	PACTware® (including Device Type Manager (DTM))
	HART® Hand Held Communicator from Emerson Process
	AMS® from Emerson Process
	PDM® from Siemens
All DTMs and drivers are available free of charge from the manufacturer's website.	
Display functions	
Operating menu	Setting the parameters using 2 measuring pages, 1 status page, 1 graphic page (measured values and graphics are freely adjustable)
Language display texts (as language package)	Standard: English, French, German, Dutch, Portuguese, Swedish, Spanish, Italian
	Eastern Europe: English, Slovenian, Czech, Hungarian
	Northern Europe: English, Danish, Polish, Finnish
	Southern Europe: English, Turkish
	China: English, German, Chinese
Russia: English, German, Russian	
Units	Metric, British and US units selectable as required from lists for volume / mass flow and counting, flow velocity, electrical conductivity, temperature

Measuring accuracy

Reference conditions	Medium: water
	Temperature: 20°C / 68°F
	Pressure: 1 bar / 14.5 psi
	Inlet section: ≥ 5 DN
Maximum measuring error	±0.5% of the measured value above 0.5 m/s; depending on the measuring sensor
	±2.5 mm/s below 0.5 m/s; independent of the measuring sensor
	For detailed information and accuracy curves, refer to chapter "Accuracy".
	Current output electronics: ±10 µA; ±100 ppm/°C (typically: ±30 ppm/°C)
Repeatability	±0.1%

Operating conditions

Temperature	
Process temperature	Refer to technical data for the measuring sensor.
Ambient temperature	Depending on the version and combination of outputs.
	It is a good idea to protect the converter from external heat sources such as direct sunlight as higher temperatures reduce the life cycle of all electronic components.
	Ambient temperatures below -25°C / -13°F may affect the readability of the display.
Storage temperature	-40...+70°C / -40...+158°F
Pressure	
Medium	Refer to technical data for the measuring sensor.
Ambient pressure	Atmosphere
Chemical properties	
Electrical conductivity	All media except for water: $\geq 5 \mu\text{S/cm}$ (also refer to the technical data for the measuring sensor)
	Water: $\geq 20 \mu\text{S/cm}$
State of aggregation	Conductive, liquid media
Solid content (volume)	$\leq 10\%$
Gas content (volume)	$\leq 3\%$
Flow rate	For detailed information, refer to chapter "Flow tables".
Other conditions	
Protection category acc. to IEC 529 / EN 60529	IP66/67 (acc. to NEMA 4/4X)

Installation conditions

Installation	For detailed information, refer to chapter "Installation conditions".
Inlet / outlet sections	Refer to technical data for the measuring sensor.
Dimensions and weight	For detailed information refer to chapter "Dimensions and weights".

Materials

Signal converter housing	Aluminium with a polyester topcoat
Measuring sensor	For housing materials, process connections, liners, grounding electrodes and gaskets, refer to technical data for the measuring sensor.

Electrical connection

General	Electrical connection is carried out in conformity with the VDE 0100 directive "Regulations for electrical power installations with line voltages up to 1000 V" or equivalent national specifications.
Power supply	100...230 VAC (-15% / +10%), 50/60 Hz; 240 VAC + 5% is included in the tolerance range.
	24 VDC (-30% / +30%)
Power consumption	AC: 15 VA
	DC: 5.6 W
Signal cable	Only necessary for remote versions.
	DS 300 (type A) Max. length: 600 m / 1950 ft (depending on electrical conductivity and measuring sensor version)
Cable entries	Standard: M20 x 1.5 (8...12 mm)
	Option: ½ NPT, PF ½

Outputs

Basic	All outputs are electrically isolated from each other and from all other circuits.
	All operating data and output values can be adjusted.
Description of abbreviations	U_{ext} = external voltage; R_L = load + resistance; U_o = terminal voltage; I_{nom} = nominal current

Current output	
Output data	Flow
Settings	Without HART®
	Q = 0%: 0...20 mA; Q = 100%: 10...21.5 mA
	Error identification: 20...22 mA
	With HART®
	Q = 0%: 4...20 mA; Q = 100%: 10...21.5 mA
Error identification: 3...22 mA	
Operating data	Basic I/Os
Active	Observe connection polarity.
	$U_{int, nom} = 20 \text{ VDC}$
	$I \leq 22 \text{ mA}$
	$R_L \leq 750 \Omega$
	HART® at terminals A
Passive	Observe connection polarity.
	$U_{ext} \leq 32 \text{ VDC}$
	$I \leq 22 \text{ mA}$
	$U_0 \leq 2 \text{ V at } I = 22 \text{ mA}$
	$R_{L, max} = (U_{ext} - U_0) / I_{max}$
	HART® at terminals A
HART®	
Description	HART® protocol via active and passive current output
	HART® version: V5
	Universal Common Practice HART® parameter: completely supported
Load	$\geq 250 \Omega$ at HART® test point; Note maximum load for current output!
Multi-drop mode	Yes, current output = 4 mA
	Multi-drop address adjustable in operation menu 1...15

Pulse or frequency output	
Output data	Flow
Function	Can be set as a pulse output or frequency output
Pulse rate/frequency	0.01...10000 pulses/s or Hz
Settings	Pulses per volume or mass unit or max. frequency for 100% flow
	Pulse width: adjustable as automatic, symmetric or fixed (0.05...500 ms)
Operating data	Basic I/Os + Modbus
Active	This output is intended to drive mechanical or electronic counters directly.
	$U_{int, nom} \leq 20 \text{ V}$ $R_V = 1 \text{ k}\Omega$ $C = 1000 \text{ }\mu\text{F}$
	High current mechanical counter $f_{max} \leq 1 \text{ Hz}$
	Low current mechanical counter $I \leq 20 \text{ mA}$ $R_L \leq 10 \text{ k}\Omega$ for $f \leq 1 \text{ kHz}$ $R_L \leq 1 \text{ k}\Omega$ for $f \leq 10 \text{ kHz}$ closed: $U_0 \geq 12.5 \text{ V}$ at $I = 10 \text{ mA}$ open: $I \leq 0.05 \text{ mA}$ at $U_{nom} = 20 \text{ V}$
Passive	Independent of connection polarity.
	$U_{ext} \leq 32 \text{ VDC}$
	f_{max} in operating menu set to $f_{max} \leq 100 \text{ Hz}$: $I \leq 100 \text{ mA}$ open: $I \leq 0.05 \text{ mA}$ at $U_{ext} = 32 \text{ VDC}$ closed: $U_{0, max} = 0.2 \text{ V}$ at $I \leq 10 \text{ mA}$ $U_{0, max} = 2 \text{ V}$ at $I \leq 100 \text{ mA}$
	f_{max} in operating menu set to $100 \text{ Hz} < f_{max} \leq 10 \text{ kHz}$: $I \leq 20 \text{ mA}$ open: $I \leq 0.05 \text{ mA}$ at $U_{ext} = 32 \text{ VDC}$ closed: $U_{0, max} = 1.5 \text{ V}$ at $I \leq 1 \text{ mA}$ $U_{0, max} = 2.5 \text{ V}$ at $I \leq 10 \text{ mA}$ $U_{0, max} = 5.0 \text{ V}$ at $I \leq 20 \text{ mA}$

Low flow cut off	
Function	Switching point and hysteresis separately adjustable for each output, counter and the display
Switching point	Set in increments of 0.1%.
	0...20% (current output, frequency output) or 0...±9.999 m/s (pulse output)
Hysteresis	Set in increments of 0.1%.
	0...5% (current output, frequency output) or 0...5 m/s (pulse output)
Time constant	
Function	The time constant corresponds to the elapsed time until 67% of the end value has been reached according to a step function.
Settings	Set in increments of 0.1s.
	0...100 s
Status output / limit switch	
Function and settings	Adjustable as automatic measuring range conversion, display of flow direction, counter overflow, error, switching point or empty pipe detection
	Valve control with activated dosing function
	Status and/or control: ON or OFF
Operating data	
Passive	Basic I/Os + Modbus
	Independent of connection polarity. $U_{ext} \leq 32 \text{ VDC}$ $I \leq 100 \text{ mA}$ open: $I \leq 0.05 \text{ mA}$ at $U_{ext} = 32 \text{ VDC}$ closed: $U_0 = 0.2 \text{ V}$ at $I \leq 10 \text{ mA}$ $U_0 = 2 \text{ V}$ at $I \leq 100 \text{ mA}$
Modbus	
Description	Modbus RTU, Master / Slave, RS485
Address range	1...247
Broadcast	Supported with function code 16
Supported Baudrate	1200, 2400, 3600, 4800, 9600, 19200, 38400, 57600, 115200 Baud

Approvals and certificates

CE	The device fulfils the statutory requirements of the EC directives. The manufacturer certifies that these requirements have been met by applying the CE marking.
Other standards and approvals	
Shock and vibration resistance	IEC 60068-2-3; EN 60068-2-6 and EN 60068-2-27; IEC 61298-3
Electromagnetic compatibility (EMC)	2004/108/EC in conjunction with EN 61326-1 (A1, A2)
European Pressure Equipment Directive	PED 97/23 (only for compact versions)
NAMUR	NE 21, NE 43, NE 53, NE 107

2.2 Dimensions and weights

2.2.1 Housing

Wall version

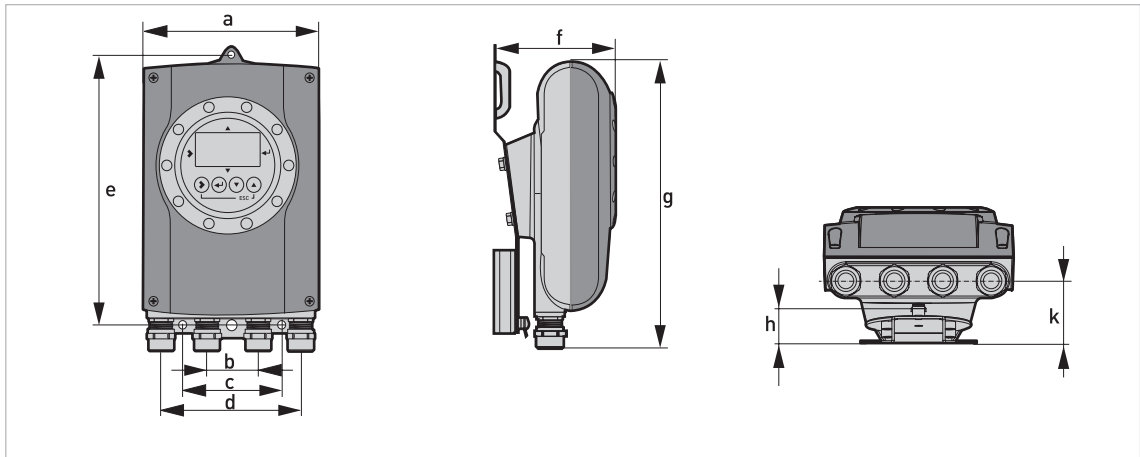

Dimensions and weights in mm and kg

	Dimensions [mm]									Weight [kg]
	a	b	c	d	e	f	g	h	k	
Version with & without display	157	40	80	120	248	111.7	260	28.4	51.3	1.9

Dimensions and weights in inch and lb

	Dimensions [inch]									Weight [lb]
	a	b	c	d	e	f	g	h	k	
Version with & without display	6.18	1.57	3.15	4.72	9.76	4.39	10.24	1.12	2.02	4.2

Compact version

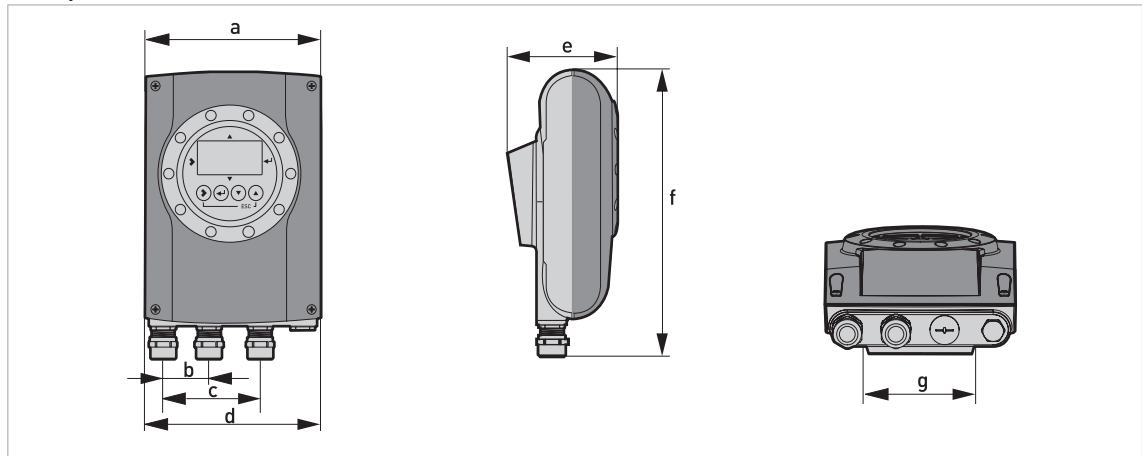

Dimensions and weights in mm and kg

	Dimensions [mm]							Weight [kg]
	a	b	c	d	e	f	g	
Version with & without display	157	40	80	148.2	101	260	95.5	1.8

Dimensions and weights in inch and lb

	Dimensions [inch]							Weight [lb]
	a	b	c	d	e	f	g	
Version with & without display	6.18	1.57	3.15	5.83	3.98	10.24	3.76	4.0

2.2.2 Mounting plate, wall version

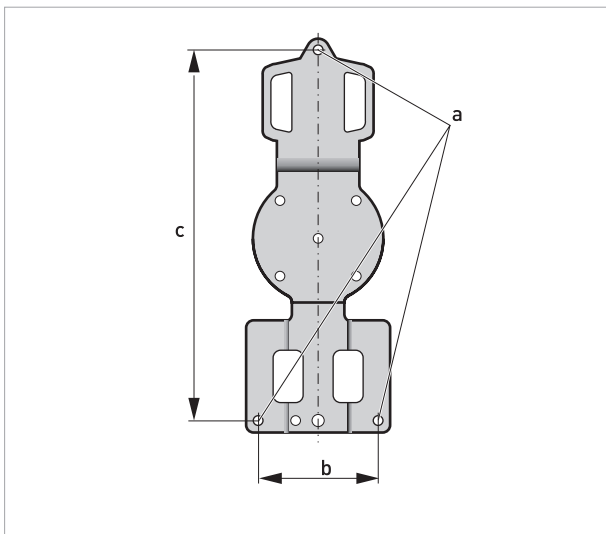

Dimensions in mm and inch

	[mm]	[inch]
a	Ø6.5	Ø0.26
b	80	3.15
c	248	9.76

2.3 Flow tables

Flow rate in m/s and m³/h

	Q _{100%} in m ³ /h			
v [m/s]	0.3	1	3	12
DN [mm]	Min. flow	Nominal flow		Max. flow
2.5	0.005	0.02	0.05	0.21
4	0.01	0.05	0.14	0.54
6	0.03	0.10	0.31	1.22
10	0.08	0.28	0.85	3.39
15	0.19	0.64	1.91	7.63
20	0.34	1.13	3.39	13.57
25	0.53	1.77	5.30	21.21
32	0.87	2.90	8.69	34.74
40	1.36	4.52	13.57	54.29
50	2.12	7.07	21.21	84.82
65	3.58	11.95	35.84	143.35
80	5.43	18.10	54.29	217.15
100	8.48	28.27	84.82	339.29
125	13.25	44.18	132.54	530.15
150	19.09	63.62	190.85	763.40
200	33.93	113.10	339.30	1357.20
250	53.01	176.71	530.13	2120.52
300	76.34	254.47	763.41	3053.64
350	103.91	346.36	1039.08	4156.32
400	135.72	452.39	1357.17	5428.68
450	171.77	572.51	1717.65	6870.60
500	212.06	706.86	2120.58	8482.32
600	305.37	1017.90	3053.70	12214.80
700	415.62	1385.40	4156.20	16624.80
800	542.88	1809.60	5428.80	21715.20
900	687.06	2290.20	6870.60	27482.40
1000	848.22	2827.40	8482.20	33928.80
1200	1221.45	3421.20	12214.50	48858.00

Flow rate in ft/s and US gallons/min

	Q ₁₀₀ % in US gallons/min			
v [ft/s]	1	3.3	10	40
DN [inches]	Min. flow	Nominal flow		Max. flow
1/10	0.02	0.09	0.23	0.93
1/8	0.06	0.22	0.60	2.39
1/4	0.13	0.44	1.34	5.38
3/8	0.37	1.23	3.73	14.94
1/2	0.84	2.82	8.40	33.61
3/4	1.49	4.98	14.94	59.76
1	2.33	7.79	23.34	93.36
1.25	3.82	12.77	38.24	152.97
1.5	5.98	19.90	59.75	239.02
2	9.34	31.13	93.37	373.47
2.5	15.78	52.61	159.79	631.16
3	23.90	79.69	239.02	956.09
4	37.35	124.47	373.46	1493.84
5	58.35	194.48	583.24	2334.17
6	84.03	279.97	840.29	3361.17
8	149.39	497.92	1493.29	5975.57
10	233.41	777.96	2334.09	9336.37
12	336.12	1120.29	3361.19	13444.77
14	457.59	1525.15	4574.93	18299.73
16	597.54	1991.60	5975.44	23901.76
18	756.26	2520.61	7562.58	30250.34
20	933.86	3112.56	9336.63	37346.53
24	1344.50	4481.22	13445.04	53780.15
28	1829.92	6099.12	18299.20	73196.79
32	2390.23	7966.64	23902.29	95609.15
36	3025.03	10082.42	30250.34	121001.37
40	3734.50	12447.09	37346.00	149384.01
48	5377.88	17924.47	53778.83	215115.30

2.4 Measuring accuracy

Reference conditions

- Medium: water
- Temperature: +20°C / +68°F
- Pressure: 1 bar / 14.5 psi
- Inlet section: ≥ 5 DN

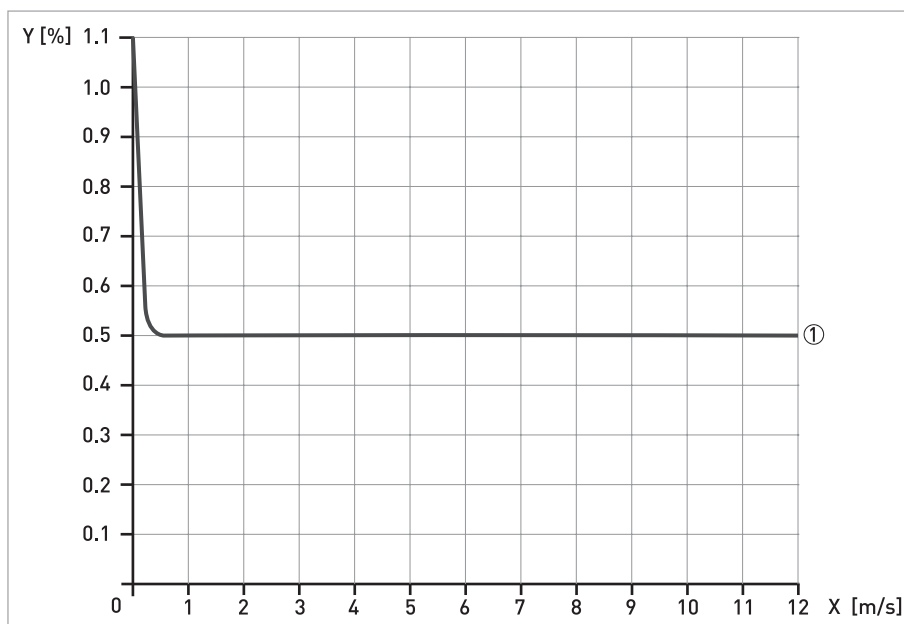

X [m/s]: flow velocity

Y [%]: deviation from the actual measured value (mv)

	DN [mm]	DN [inch]	Accuracy	Curve
OPTIFLUX 2050	10...1200	3/8...48	0.5% of measured value above 0.5 m/s ①	①
OPTIFLUX 1050	10...150	3/8...6		
WATERFLUX 3050	25...600	1...24		

① below 0.5 m/s, deviation of ± 2.5 mm/s

3.1 Intended use

The electromagnetic flowmeters are designed exclusively to measure the flow and conductivity of electrically conductive, liquid media.

If the device is not used according to the operating conditions (refer to chapter Technical data), the intended protection could be affected.

3.2 Installation specifications

The following precautions must be taken to ensure reliable installation.

- *Make sure that there is adequate space to the sides.*
- *Protect the signal converter from direct sunlight and install a sun shade if necessary.*
- *Signal converters installed in control cabinets require adequate cooling, e.g. by fan or heat exchanger.*
- *Do not expose the signal converter to intense vibration. The flowmeters are tested for a vibration level in accordance with IEC 68-2-64.*

3.3 Mounting of the compact version

The signal converter is mounted directly on the measuring sensor. For installation of the flowmeter, please observe the instructions in the supplied product documentation for the measuring sensor.

3.4 Mounting of the wall housing, remote version

Assembly materials and tools are not part of the delivery. Use the assembly materials and tools in compliance with the applicable occupational health and safety directives.

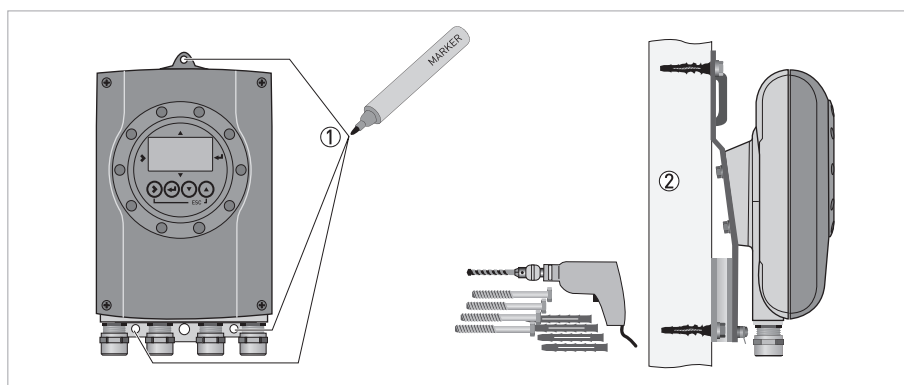
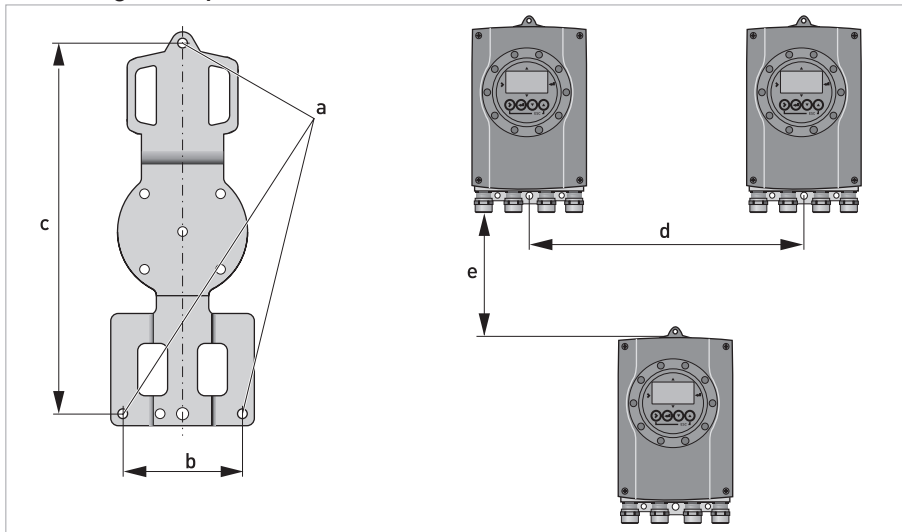

Figure 3-1: Mounting of the wall housing

- ① Prepare the holes with the aid of the mounting plate.
- ② Fasten the device securely to the wall with the mounting plate.

Mounting multiple devices next to each other



	[mm]	[inch]
a	Ø6.5	Ø0.26
b	80	3.15
c	248	9.76
d	310	12.2
e	257	10.1

4.1 Safety instructions

All work on the electrical connections may only be carried out with the power disconnected. Take note of the voltage data on the nameplate!

Observe the national regulations for electrical installations!

Observe without fail the local occupational health and safety regulations. Any work done on the electrical components of the measuring device may only be carried out by properly trained specialists.

Look at the device nameplate to ensure that the device is delivered according to your order. Check for the correct supply voltage printed on the nameplate.

4.2 Preparing the signal and field current cables

Assembly materials and tools are not part of the delivery. Use the assembly materials and tools in compliance with the applicable occupational health and safety directives.

4.2.1 Signal cable A (type DS 300), construction

- Signal cable A is a double-shielded cable for signal transmission between the measuring sensor and signal converter.
- Bending radius: $\geq 50 \text{ mm} / 2''$

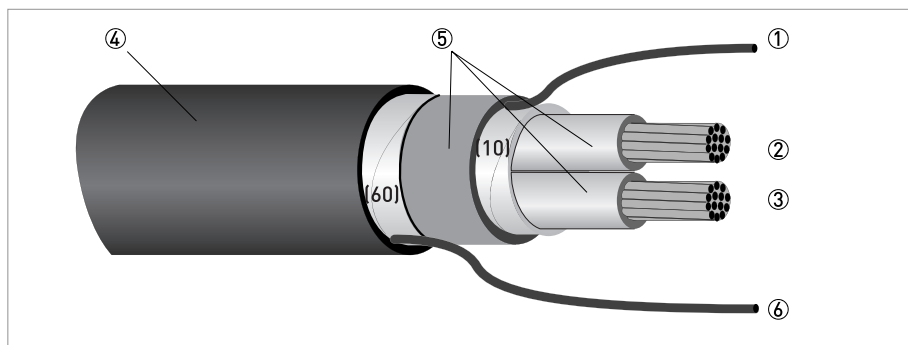

Figure 4-1: Construction of signal cable A

- ① Stranded drain wire (1) for the inner shield (10), $1.0 \text{ mm}^2 \text{ Cu} / \text{AWG } 17$ (not insulated, bare)
- ② Insulated wire (2), $0.5 \text{ mm}^2 \text{ Cu} / \text{AWG } 20$
- ③ Insulated wire (3), $0.5 \text{ mm}^2 \text{ Cu} / \text{AWG } 20$
- ④ Outer sheath
- ⑤ Insulation layers
- ⑥ Stranded drain wire (6) for the outer shield (60)

4.2.2 Length of signal cable A

For temperatures of the medium above 150°C / 300°F, a special signal cable and a ZD intermediate socket are necessary. These are available including the changed electrical connection diagrams.

Measuring sensor	Nominal meter size		Min. electrical conductivity [$\mu\text{S}/\text{cm}$]	Curve for signal cable A
	DN [mm]	[inch]		
OPTIFLUX 1000 F	10...150	3/8...6	20	A1
OPTIFLUX 2000 F	25...150	1...6	20	A1
	200...1200	8...48	20	A2
WATERFLUX 3000 F	25...600	1...24	20	A1

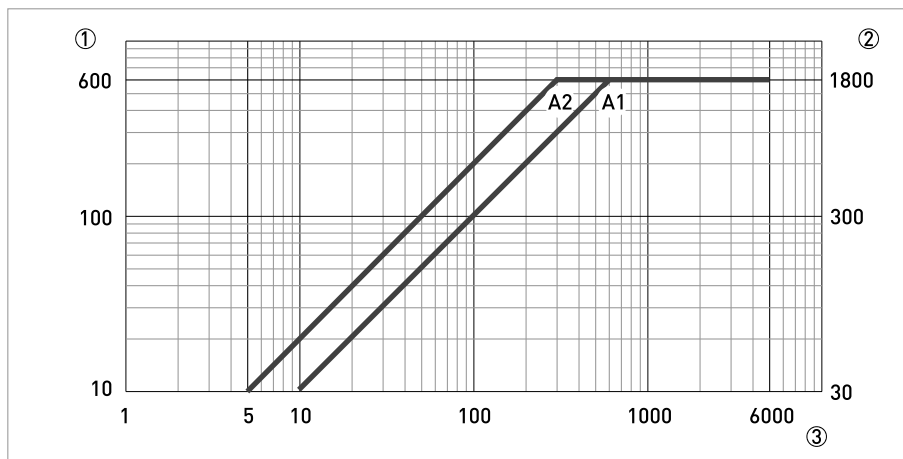

Figure 4-2: Maximum length of signal cable A

- ① Maximum length of signal cable A between the measuring sensor and signal converter [m]
- ② Maximum length of signal cable A between the measuring sensor and signal converter [ft]
- ③ Electrical conductivity of the medium being measured [$\mu\text{S}/\text{cm}$]

4.2.3 Connection diagram for signal and field current cable

The device must be grounded in accordance with regulations in order to protect personnel against electric shocks.

- A shielded 2-wire copper cable is used as the field current cable. The shielding **MUST** be connected in the housing of the measuring sensor and signal converter.
- The outer shield (60) is connected in the terminal compartment of the measuring sensor directly via the shield and a clip.
- Bending radius of signal and field current cable: $\geq 50 \text{ mm} / 2''$
- The following illustration is schematic. The positions of the electrical connection terminals may vary depending on the housing version.

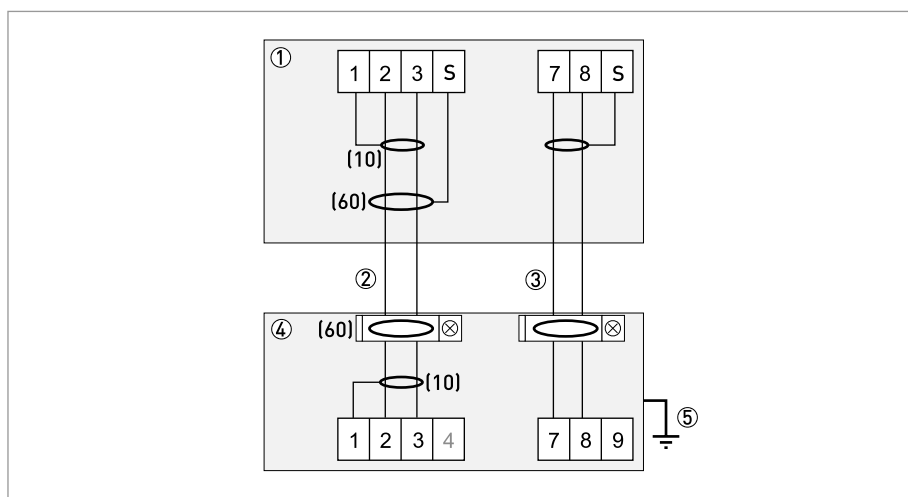

Figure 4-3: Connection diagram for signal and field current cable

- ① Electrical terminal compartment in signal converter
- ② Signal cable A
- ③ Field current cable C
- ④ Electrical terminal compartment in measuring sensor
- ⑤ Functional ground FE

4.3 Grounding the measuring sensor

There should be no difference in potential between the measuring sensor and the housing or protective earth of the signal converter!

- The measuring sensor must be properly grounded.
- The grounding cable should not transmit any interference voltages.
- Do not use the grounding cable to connect any other electrical devices to ground at the same time.
- The measuring sensors are connected to ground by means of a functional grounding conductor FE.
- Special grounding instructions for the various measuring sensors are provided in the separate documentation for the measuring sensor.
- The documentation for the measuring sensor also contain descriptions on how to use grounding rings and how to install the measuring sensor in metal or plastic pipes or in pipes which are coated on the inside.

4.4 Connecting the power supply

- *To protect operators from electrical shock, during installation the cable for the power supply **must** be run with sheathing insulation up to the mains cover. The insulated individual wires have to be only below the mains cover!*
- *If there is no mains cover or if it has been lost, the 100...230 VAC device may only be operated from the outside (with a bar magnet) while closed!*
- The housings of the devices, which are designed to protect the electronic equipment from dust and moisture, should be kept well closed at all times. Creepage distances and clearances are dimensioned to VDE 0110 and IEC 664 for pollution severity 2. Supply circuits are designed for overvoltage category III and the output circuits for overvoltage category II.
- Fuse protection ($I_N \leq 16$ A) for the infeed power circuit, and also a separator (switch, circuit breaker) to isolate the signal converter must be provided.

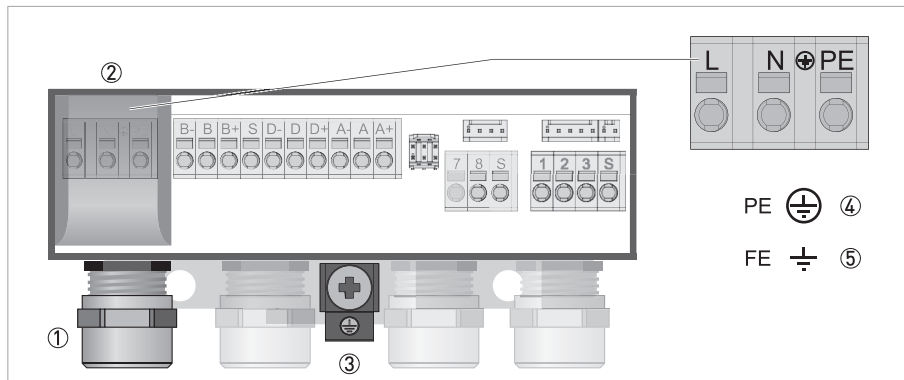

Figure 4-4: Terminal compartment for power

- ① Cable entry for power supply
- ② Mains cover
- ③ Ground terminal
- ④ 100...230 VAC (-15% / +10%)
- ⑤ 24 VDC (-30% / +30%)

- To open the cover of the electrical terminal compartment, lightly press in the side walls of the mains cover ②.
- Flip the mains cover up.
- Connect the power supply.
- Close the mains cover again by flipping it down.

100...230 VAC (tolerance range: -15% / +10%)

- Note the power supply voltage and frequency (50...60 Hz) on the nameplate.

240 VAC + 5% is included in the tolerance range.

24 VDC (tolerance range: -30% / +30%)

- Note the data on the nameplate!
- When connecting to functional extra-low voltages, provide a facility for protective separation (PELV) (acc. to VDE 0100 / VDE 0106 and/or IEC 364 / IEC 536 or relevant national regulations).

4.5 Overview of outputs

4.5.1 Description of the CG number



Figure 4-5: Marking (CG number) of the electronics module and output variants

- ① ID number: 1
- ② ID number: 0 = standard; 9 = special
- ③ Power supply
- ④ Display (language versions)
- ⑤ Output version

4.5.2 Fixed, non-alterable output versions

This signal converter is available with various output combinations.

- The grey boxes in the tables denote unassigned or unused connection terminals.
- In the table, only the final digits of the CG no. are depicted.
- Terminals D- and A- are connected for active pulse/frequency output (no galvanic isolation anymore).

Basic outputs (I/Os)

CG no.	Connection terminals							
	S	D-	D	D+	A-	A	A+	
1 0 0 R 0 0	①	P _p / S _p passive				I _p + HART® passive ②		
		connected to A-	P _a active			connected to D-	I _a + HART® active ②	
		P _p / S _p passive					I _a + HART® active ②	

① Shielding

② Function changed by reconnecting

Modbus (I/O) (option)

CG no.	Connection terminals			
	B-	B	B+	S
R 0 0	Sign. A (D0-)	Common	Sign. B (D1+)	Shielding

Description of used abbreviations

I _a	I _p	Current output active or passive
P _a	P _p	Pulse/frequency output active or passive
S _a	S _p	Status output/limit switch active or passive

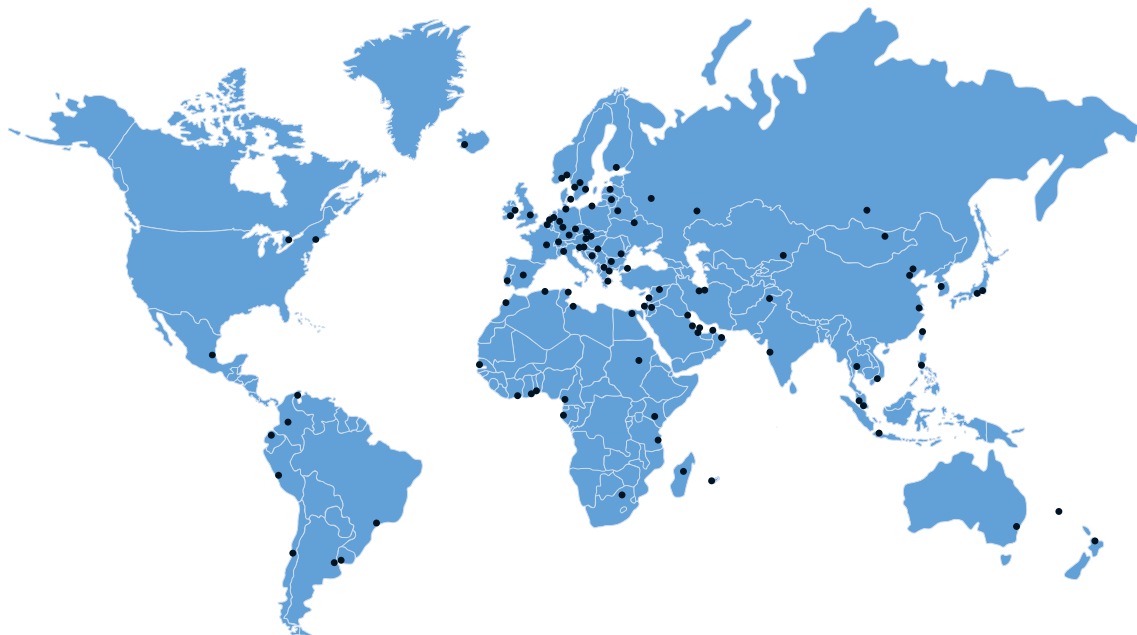

KROHNE product overview

- Electromagnetic flowmeters
- Variable area flowmeters
- Ultrasonic flowmeters
- Mass flowmeters
- Vortex flowmeters
- Flow controllers
- Level meters
- Temperature meters
- Pressure meters
- Analysis products
- Products and systems for the oil & gas industry
- Measuring systems for the marine industry

Head Office KROHNE Messtechnik GmbH
Ludwig-Krohne-Str. 5
47058 Duisburg (Germany)
Tel.: +49 (0)203 301 0
Fax: +49 (0)203 301 10389
info@krohne.de

The current list of all KROHNE contacts and addresses can be found at:
www.krohne.com

KROHNE